



Appendix 1—Rockwell/Brinell Hardness Conversion

If the work materials hardness is available in Rockwell B (HRB) or Rockwell C (HRC) numbers, they should be converted into Brinell hardness numbers by the following equations shown in Table A and Table B.

Table A. Brinell–Rockwell C Hardness Relationship

Rockwell C Hardness Numbers (HRC)		Equations to Convert Rockwell C Hardness (HRC) into Brinell Hardness (HB)
from	to	
21	30	$HB = 5.970 \times HRC + 104.7$
31	40	$HB = 8.570 \times HRC + 27.6$
41	50	$HB = 11.158 \times HRC + 79.6$
51	60	$HB = 17.515 \times HRC - 401$

Table B. Brinell–Rockwell B Hardness Relationship

Rockwell B Hardness Numbers (HRB)		Equations to Convert Rockwell B Hardness (HRB) into Brinell Hardness (HB)
from	to	
55	69	$HB = 1.646 \times HRB + 8.7$
70	79	$HB = 2.394 \times HRB - 42.7$
80	89	$HB = 3.297 \times HRB - 114$
90	100	$HB = 5.582 \times HRB - 319$

Appendix 2—Engagement Angle and Number of Inserts in Cut

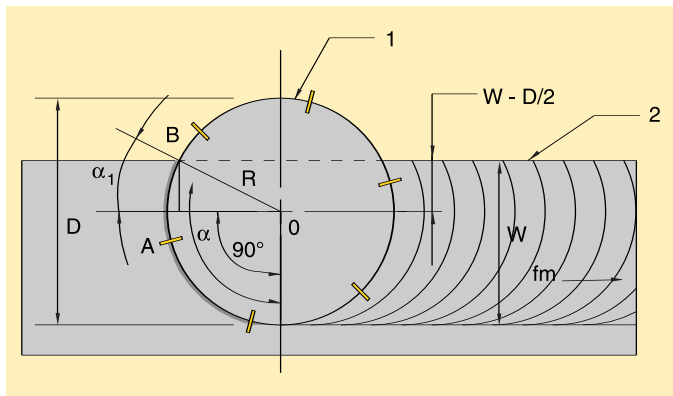

$$D/2 < W < D$$

$$Z_c = \frac{Z \times \alpha^\circ}{360^\circ} \quad \alpha = 90^\circ + \alpha_1$$

$$\sin \alpha_1 = \frac{AB}{OB} = \frac{W - D/2}{D/2} = \frac{2(W - D/2)}{D} = \frac{2W - D}{D}$$

$$\alpha_1 = \arcsin \frac{2W - D}{D}$$

$$Z_c = \frac{Z \left(90^\circ + \arcsin \frac{2W - D}{D} \right)}{360^\circ}$$

D = cutter diameter

W = width of cut (woc)

α = engagement angle

α_1 = angle between cutter centerline and cutter radius to the peripheral point of exit or entry

Z = number of inserts in cutter

Z_c = number of inserts in cut

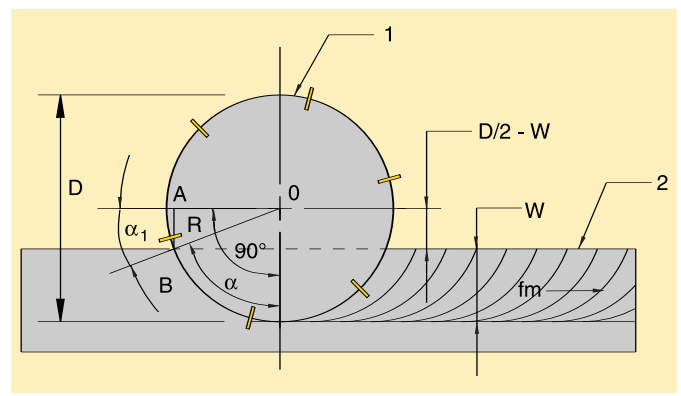

$$W < D/2$$

$$Z_c = \frac{Z \times \alpha^\circ}{360^\circ} \quad \alpha = 90^\circ - \alpha_1$$

$$\sin \alpha_1 = \frac{AB}{OB} = \frac{D/2 - W}{D/2} = \frac{2(D/2 - W)}{D} = \frac{D - 2W}{D}$$

$$\alpha_1 = \arcsin \frac{D - 2W}{D}$$

$$Z_c = \frac{Z \left(90^\circ - \arcsin \frac{D - 2W}{D} \right)}{360^\circ}$$