

KENNA PERFECT™ Application Guide for High-Performance Tapping



Note: These are starting recommendations for hole depths no greater than 1.5 times the cutting diameter.

Low Carbon Steels (< .25% C) Free Machining Steels (< 275 HB) Medium and High Plain Carbon, Alloy, and Tool Steels (≤ 35 HRC)		Medium and High Plain Carbon, Alloy, and Tool Steels (36-48 HRC) Ferritic, Martensitic, and PH Stainless Steels (< 375 HB) (< 40 HRC)	
<p>through hole</p> <p>spiral point plug</p>	<p>blind hole</p> <p>spiral flute modified bottom spiral flute full bottom</p>	<p>through hole</p> <p>spiral point plug</p>	<p>blind hole</p> <p>spiral flute modified bottom spiral flute full bottom</p>
<p>K-SS 45-75 sfm Pages H352-H356</p>	<p>K-SS 25-45 sfm Pages H357-H365</p>	<p>K-NI 15-35 sfm Pages H366-H367</p>	<p>K-NI 10-25 sfm Pages H368-H370</p>

Austenitic Stainless Steels (135-275 HB) (≤ 28 HRC)

<p>through hole</p> <p>spiral point plug</p>	<p>blind hole</p> <p>spiral flute modified bottom spiral flute full bottom</p>
<p>K-SS 30-45 sfm Pages H352-H356</p>	<p>K-SS 15-30 sfm Pages H357-H365</p>

Ductile and Malleable Cast Irons (120-320 HB) Gray Cast Irons (120-320 HB)







<p>through hole</p> <p>spiral point plug</p>	<p>blind hole</p> <p>spiral flute modified bottom spiral flute full bottom</p>	<p>through hole</p> <p>straight flute plug</p>	<p>blind hole</p> <p>straight flute full bottom</p>
<p>K-SS 25-50 sfm Pages H352-H356</p>	<p>K-SS 10-35 sfm Pages H357-H365</p>	<p>K-CI (solid carbide) 45-70 sfm Pages H380-H381</p>	<p>K-CI (solid carbide) 30-55 sfm Pages H382-H383</p>



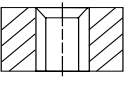

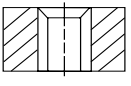

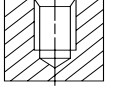

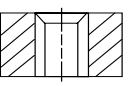

KENNA PERFECT™ Application Guide for High-Performance Tapping

Note: These are starting recommendations for hole depths no greater than 1.5 times the cutting diameter.

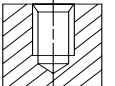

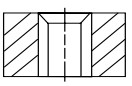

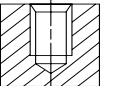
High-Silicon Aluminum Alloys (Hypereutectic > 12.2% Si)

<p>through hole</p>   <p>plug chamfer 4-5 pitches</p>	<p>through hole</p>   <p>straight flute plug full bottom</p>	<p>blind hole</p>   <p>straight flute</p>
<p>K-AI 40-115 sfm Pages H374-H377</p>	<p>K-AA (solid carbide) 40-80 sfm Pages H386-H387</p>	<p>K-AA (solid carbide) 15-40 sfm Pages H384-H385</p>

<h3>Nickel-Base, Heat-Resistant Alloys (140-475 HB) (≤ 48 HRC)</h3>	<h3>Titanium and Titanium Alloys, Magnesium (110-450 HB) (≤ 48 HRC)</h3>
---	--

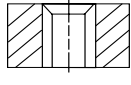
<p>through hole</p>   <p>spiral point plug</p>	<p>blind hole</p>    <p>spiral flute modified bottom spiral flute full bottom</p>	<p>through hole</p>   <p>LH spiral, RH cut plug</p>	<p>blind hole</p>   <p>spiral flute modified bottom</p>
<p>K-NI 15-30 sfm Pages H366-H367</p>	<p>K-NI 5-10 sfm Pages H368-H370</p>	<p>K-TI 15-30 sfm Pages H388-H389</p>	<p>K-TI 5-10 sfm Pages H390-H391</p>

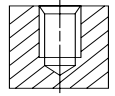
Hardened Steels and Irons (36-45 HRC)

<p>through hole</p>   <p>mold hand taps</p>	<p>blind hole</p>   <p>mold hand taps</p>
<p>K-MS 15-35 sfm Page H378</p>	<p>K-MS 10-25 sfm Page H378</p>