

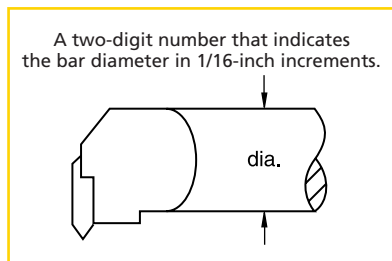

LT
 TOP NOTCH
 TECHNICAL DATA
 THREADING TOOLS

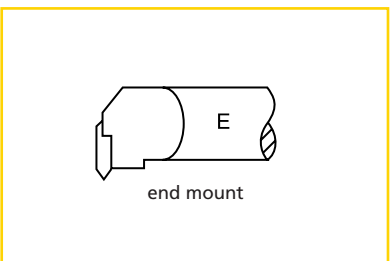

2. Bar Diameter



4. Insert Location

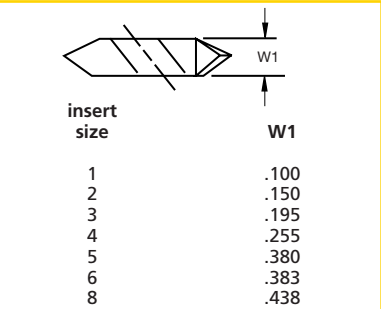

6. Insert Size

S 32

1. Bar Type

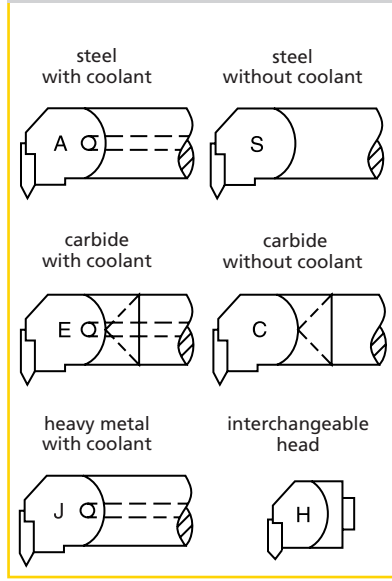

N E

3. Insert Holding Method

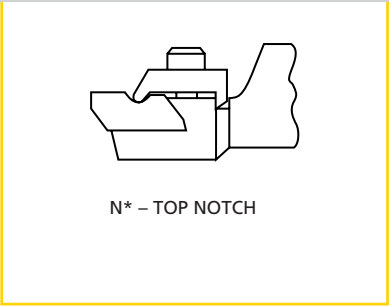

R

5. Hand of Bar

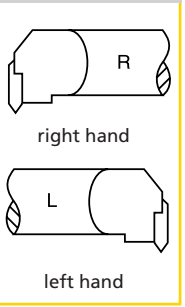

3 W

7. Additional Information

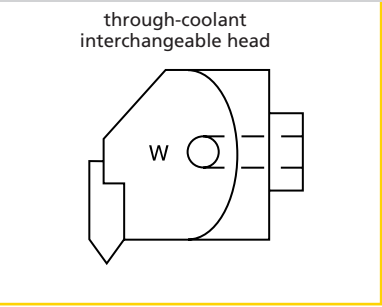

*Kennametal standard only.

NOTE: Right-hand bars use left-hand inserts and clamps.
Left-hand bars use right-hand inserts and clamps.