

**Inch Series Socket Pressure Plugs
Dryseal Type (3/4 taper)**

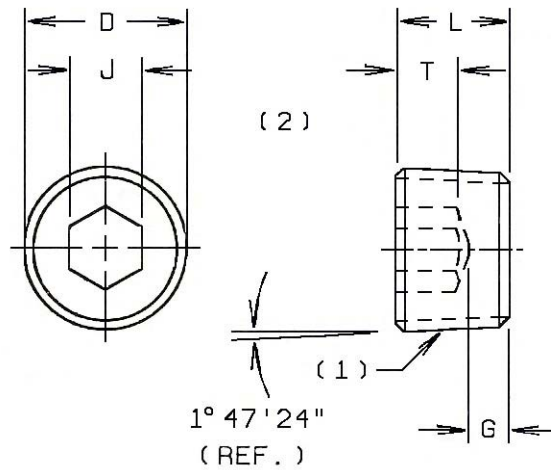

Nominal Size	D Nominal Outside Diameter	Threads Per Inch	J Hex Socket Size	T Key Engagement Min.	G Wall Thickness Min.	L Length		
						Nom.	Max.	Min.
1/16	.312	27	5/32	0.140	0.062	0.312	0.324	0.300
1/8	.405	27	3/16	0.140	0.062	0.312	0.324	0.300
1/4	.540	18	1/4	0.218	0.073	0.438	0.457	0.417
3/8	.675	18	5/16	0.250	0.084	0.500	0.520	0.480
1/2	.840	14	3/8	0.312	0.095	0.562	0.582	0.542
3/4	1.050	14	9/16	0.312	0.125	0.625	0.645	0.605
1	0.315	11 1/2	5/8	.0375	0.125	0.750	0.770	0.730
1 1/4	0.660	11 1/2	3/4	0.437	0.156	0.812	0.832	0.792
1 1/2	1.900	11 1/2	1	0.437	0.156	0.812	0.843	0.780
2	2.375	11 1/2	1	0.437	0.156	0.875	0.906	0.844

Applicable Standards: ASME B2.2 and B1.20.3.

Notes on Inch Series Socket Pressure Plugs-Dryseal Type

1. Threads conform to the American Standard Taper Dryseal Pipe Thread NPTF in accordance with requirements of ASME B2.2.
2. NPTF – letters apply as follows:
 N- National standard (USA)
 P – Pipe
 T- Taper
 F – Fuel and Oil
3. 3/4 - 0.750 inch taper per 12 inches

Inch Series Socket Pressure Plugs Flush type (7/8 Taper)

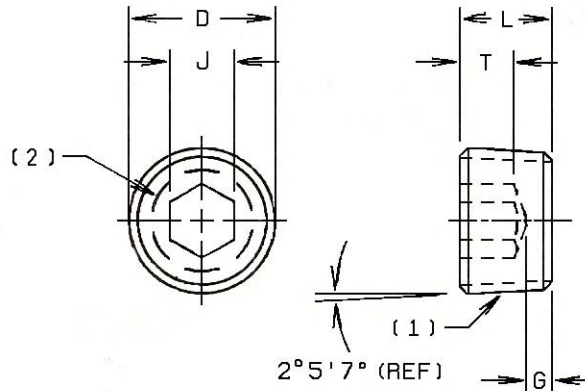

Nominal Size	D Nominal O.D.	Threads Per Inch	J Hex Socket Size	T Key Engagement Min.	G Wall Thickness Min.	L Overall Length		Basic Pitch Diameter At Socket Face
						Max.	Min.	
1/16	0.037	27	5/32	0.140	0.052	0.250	0.235	0.28253
1/8	0.401	27	3/16	0.140	0.049	0.250	0.235	0.37495
1/4	0.529	18	1/4	0.218	0.045	0.406	0.391	0.49366
3/8	0.667	18	5/16	0.250	0.040	0.406	0.391	0.62904
1/2	0.830	14	3/8	0.312	0.067	0.531	0.516	0.78103
3/4	1.041	14	9/16	0.312	0.054	0.531	0.516	0.99147

Applicable Standards: ASME B2.2.

Notes for Inch Series Socket Pressure Plugs – Flush Type 7/8 taper

1. Threads conform to ASME B18.2.2 Dryseal Taper Pipe Thread Taper 7/8 inch diametral per foot.
2. Six equally spaced identification grooves are located equidistant between corners of hex socket and edge of chamfer. On 1/16-27 plugs 3 grooves are permitted because of space limitations.

PTF letter designations:

P- Plug
T-Taper
F- Flush

7/8 – 0.875 inch taper per 12 inches

Inch Series Socket Pressure Plugs (continued)

Comparison between Dryseal Type and Flush Type Pressure Plugs

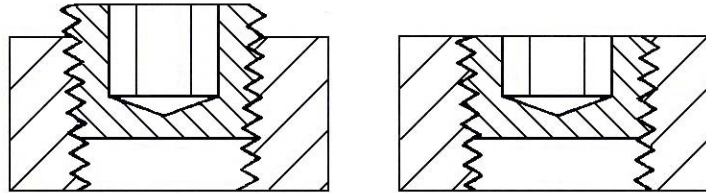

NPTF

PTF

The Dryseal, or 3/4 taper plug is longer than the flush type and is most commonly used because it better fits holes that are not as accurately tapped.

The Flush Type or 7/8 taper plug has tighter thread tolerances than the Dryseal type and is meant to be flush or level with the top of the tapped mating hole.

Inch Series Pressure Plug Application Information

Nominal Size	Threads Per Inch	Hex Key Size	Tap Drill Size Without Use Of Reamer	Tap Drill Size With Use Of Reamer	Tightening Torque Inch-Pounds
1/16	27	5/32	0.246	0.234	120
1/8	27	3/16	0.339	0.328	200
1/4	18	1/4	0.438	0.422	480
3/8	18	5/16	0.578	0.562	960
1/2	14	3/8	0.703	0.688	1440
3/4	14	9/16	0.922	0.891	2400
1	11 1/2	5/8	1.156	1.125	3360
1 1/4	11 1/2	3/4	1.500	1.469	4320
1 1/2	11 1/2	1	1.734	1.703	5520
2	11 1/2	1	--	--	6800